

Digital Module ADN 410



Outline description: ADN 410 CNC module

The **ADN 410** has been developed as a CNC control system for operation with a servo-valve. The assembly consists of two modules, of types MD3 and MD14. The MD3 is the basic module (equivalent to the **ADN 404**). The MD14 is the add-on CNC module. The MD14 CNC module is also used in other device combinations, due to the modular structure of this system. The **ADN 404** basic module has, in this particular case, already been described, with the result that this outline description relates primarily to the add-on module.

The MD14 CNC module is equipped with an SSI interface for operation with an absolute position encoder, such as absolute shaft encoders or Temposonic, for example. An interface which permits incremental position measurement has also been included. Position measurement uses an A and a B channel for recognition of direction, with the result that correct detection of zero is possible using the index in conjunction with a limit switch.

The pulse generator is supplied with 24V from the **ADN 410** module. The MD14 CNC module is equipped with its own signal processor, which has a processing speed of 40 MIPS. Four further inputs and four outputs are also provided, signifying that the **ADN 410** device com-

bination has a total of 11 inputs and 5 outputs. A Profibus DP can be used optionally. The necessary GSD file is provided if a Profibus is used.

The **ADN 410** device has been created by combining the MD1 (**ADN 404**) and the MD14. It has a width of 45 mm and is suitable for installation on DIN 50022 rails.

The **ADN 410** is equipped with two microprocessors, each of 40 MIPS. The combination of digital and analog sensors is therefore possible in special cases, without overloading the microprocessors' processing speed.

The **ADN 410** is equipped with the CAN bus, which permits communication of a large number of devices with one another. Augmentation of such a group of devices with the Profibus assures an interface to the majority of PLC control systems.

As already mentioned in the outline description of the **ADN 404**, the MD3 basic module is equipped with an output stage for a servo-valve. The output stage can be set in the graduations of $\pm 20\text{mA}$, $\pm 50\text{mA}$, $\pm 100\text{mA}$ and $\pm 200\text{mA}$ using a 0 Ohm resistor. Fine matching of valve current is performed using the **ADN configurator**.

An internal function generator, the frequency of which can be selected from 0.1 to 50Hz, is provided for controller optimization. The generator supplies sinusoidal, triangular and square waves. Amplitude and offset can be entered at $\pm 10\text{V}$.

All settings on the **ADN 404** are effected using the **ADN configurator** via an **RS232** interface linked to a PC or laptop computer.

The input software **ADN configurator** is available on the Internet.

Further information:

Pees Components GmbH

Paschenfurth 4 D-47506 Neukirchen-Vluyn

Tel: +49(0)2845-94960

GERMANY

Fax: +49(0)2845-9496-29

e-mail: info@pees.com

www.pees.com

PEES

COMPONENTS

Digital Module ADN 410

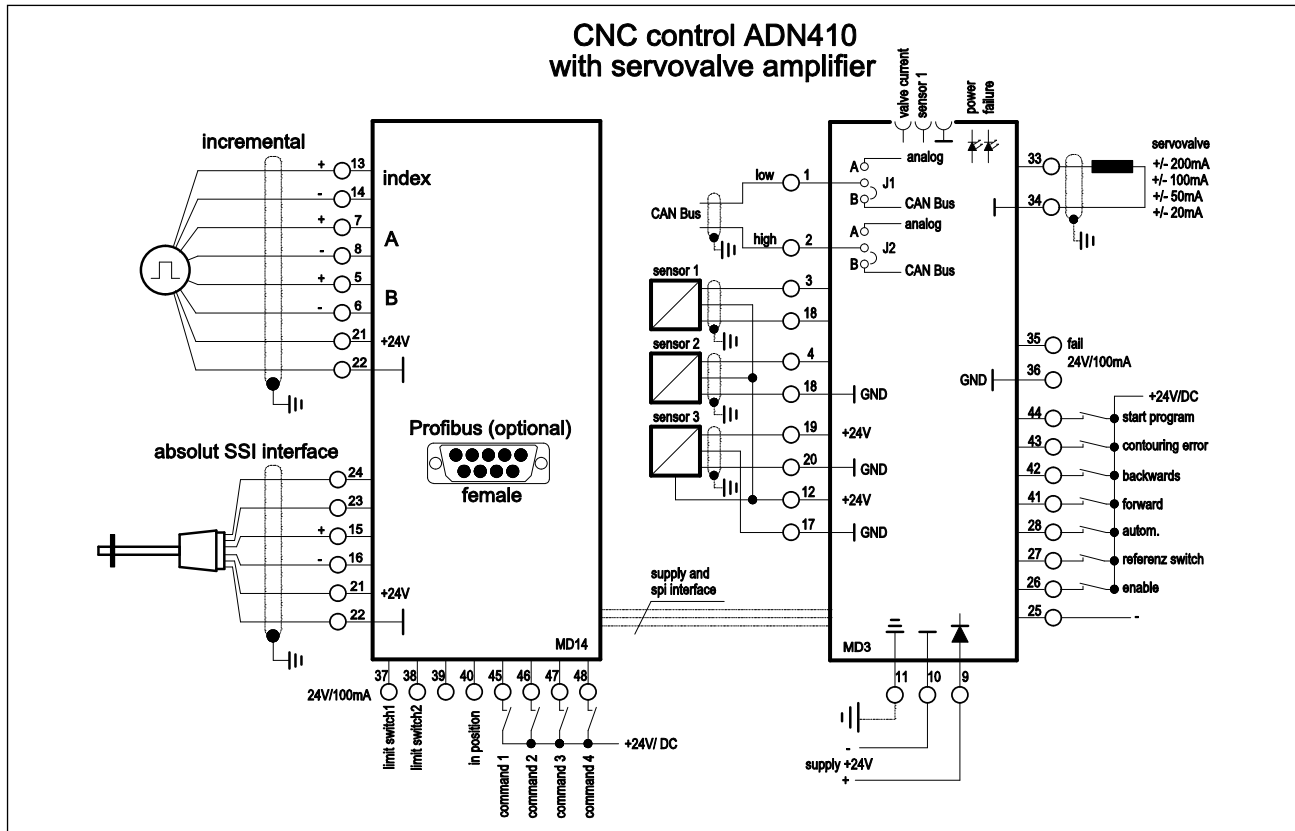

Technical data:

Supply voltage	24V DC, nominal (22 to 28V) DC
Bias current (idling)	approx. 130mA
Auxiliary voltage	22 to 28V DC for supply of the sensors sustained short-circuit-proof via a 0.5A resettable fuse
Output signal	can be entered in four ranges +/- 20mA to +/- 200mA
Inputs	11, opto-decoupled
Outputs	5 x 24V/100mA
Measuring sockets	The valve current can be measured at +/- 20mA = +/- 10V, +/- 50mA = +/- 10V, etc., on Measuring Socket M1. Sensor 1 can be measured on M2.
Ambient temperature	-20 to +60°C
Microprocessors	2 x 16 bit signal processors, each with a processing speed of 40 MIPS
Program cycle time	9.7kHz for the entire computer program, approx. 0.1 ms
Controller setting range	1 to 32000 for P, I, DT1
Sensor modules for MD3	±10V, 12mA ±8mA, 4-20mA, 0-10V, 7.5V ±4V
Fault signalization	Wire breakage in modules 12mA ±8mA 4-20mA 7.5V±4V in case of short-circuit in the sensor supply. Signalization via a 24V/100mA output, flashing red LED and display on the ADN configurator
Parametering	Parameters are entered on the ADN configurator . This input software is available via the Internet.
Position encoder	absolute, via SSI interface, or incremental, via pulse generator
Field bus	CAN bus for external and internal communication Profibus DP (optional) for communication with PLC control system or external sensors

An USB-to-RS232 adapter is required for use with laptops with a USB interface.