

## Digital Module ADN 409



### Outline description: ADN 409

The **ADN 409** has been developed as a CNC control system for operation with a directional proportional valve. The assembly consists of two modules, of types MD1 and MD14. The MD1 module is the basic module (equivalent to the **ADN 402**). The MD14 is the CNC expansion module. The MD14 CNC module is also used in other device combinations, due to the modular structure of this system.

The **ADN 402** basic module has, in this particular case, already been described, and the following outline description therefore relates primarily to the add-on module.

The MD14 CNC module is equipped with an SSI interface for operation with an absolute position encoder, such as absolute shaft encoders or Temposonic, for example. In addition, a pulse generator interface which permits incremental position measurement has also been included. This position measurement system uses an A and a B channel for detection of direction. Correct detection of zero is possible by means of an index signal.

The pulse generator is supplied with 24V from the **ADN 409** device. The MD14 CNC module is equipped with its own signal processor, which has a processing speed of 40 MIPS. A further four inputs and four outputs have also been included, signifying that the **ADN 409** CNC control system has a total of ten inputs and five outputs.

The use of a Profibus DP is also possible as an option. The necessary GSD file is provided if a Profibus is used.

The **ADN 409** device has been created by combining the MD1 (**ADN 402**) and the MD14. It has a width of 45 mm and is suitable for installation on DIN 50022 rails.

The **ADN 409** is equipped with two microprocessors, each of 40 MIPS; in special cases, a combination of digital and analog sensors is therefore possible without impairing the microprocessors' processing speed.

The **ADN 409** is equipped with the CAN bus, which permits communication of a large number of devices with one another. Augmentation of such a group of devices with the Profibus assures interface-capability with the majority of PLC control systems.

As already mentioned in the outline description of the **ADN 402**, the MD1 basic module is equipped with output stages for proportional valves up to 3000mA. The output stages feature fast de-excitation, which permits de-excitation of the valve current within 2 to 4ms.

All settings on the **ADN 409** are effected using the **ADN configurator** via an **RS232** interface linked to a PC or laptop computer.

The input software **ADN configurator** is available on the Internet.

Further information:

**Pees Components GmbH**

Paschenfurth 4 D-47506 Neukirchen-Vluyn

Tel: +49(0)2845-94960

GERMANY

Fax: +49(0)2845-9496-29

e-mail: info@pees.com

www.pees.com

# PEES

## COMPONENTS

### Digital Module ADN 409

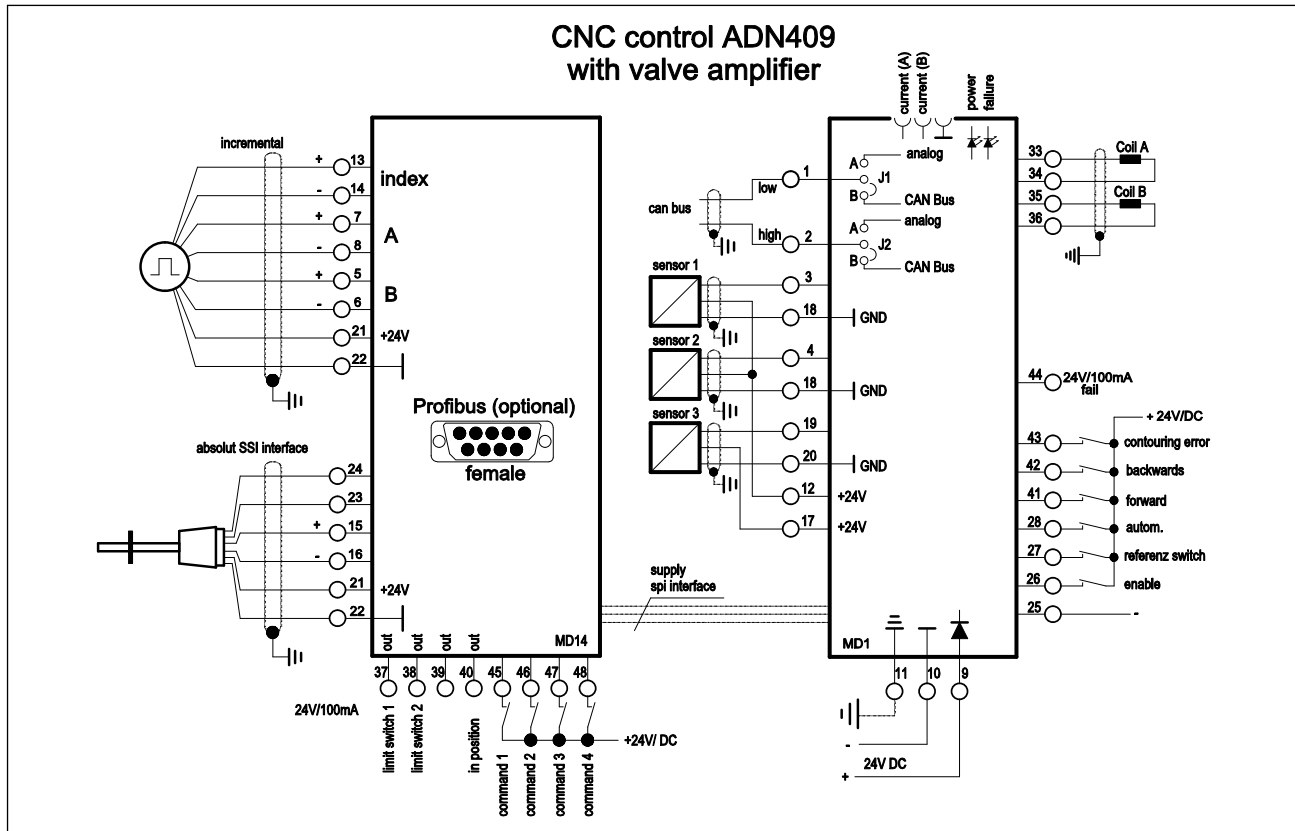

#### Technical data:

Supply voltage	24V DC, nominal (22 to 28V) DC
Bias current (idling)	approx. 70 mA
Auxiliary voltage	22 to 28V DC for supply of the sensors, sustained short-circuit-proof via 0.5A resettable fuse
Output signal	850mA, 1200mA, 1600mA, 1800mA, 2100mA, 3000mA
Inputs	10 opto-decoupled
Outputs	5 x 24V/100mA
Measuring sockets	The output current of the A and B magnets can be measured at 1V/A on Measuring Sockets M1 and M2
Ambient temperature	-20 to +60°C
Microprocessors	2 x 16 bit signal processors, each with a processing speed of 40 MIPS
Program cycle time	9.7 kHz for the entire computer program, approx. 0.1 ms
Controller setting range	1 to 32000 for P, I, DT1
Function generator	Sinusoidal, triangular and square-wave generator, with offset and amplitudes setting of ±10V, frequency range is 0.1 to 50Hz
Sensor modules for MD1	±10V, 12mA ±8mA, 4-20mA, 0-10V, 7.5V ±4V
Fault signalization	Wire breakage in modules 12mA ±8mA 4-20mA 7.5V ±4V in case of short-circuit in the sensor supply. Signalization via a 24V/100mA output, flashing red LED and display on the <b>ADN configurator</b>
Parametering	Parameters are entered on the <b>ADN configurator</b> . This input software is available via the Internet.
Position encoder	absolute, via SSI interface or incremental, via pulse generator
Field bus	CAN bus for external and internal communication Profibus DP (optional) for communication with PLC control system or external sensors

An USB-to-RS232 adapter is required for use with laptops with a USB interface.